

Model ESFR-22 22.4 K-factor Pendent Rapid Install Sprinkler Early Suppression, Fast Response

IMPORTANT

Refer to *Technical Data Sheet TFP2300* for warnings pertaining to regulatory and health information.

Always refer to *Technical Data Sheet TFP700* for the "INSTALLER WARNING" that provides cautions with respect to handling and installation of sprinkler systems and components. Improper handling and installation can permanently damage a sprinkler system or its components and cause the sprinkler to fail to operate in a fire situation or cause it to operate prematurely.

Scan the QR code or enter the URL in a web browser to access the most up-to-date electronic version of this document. Data rates may apply.



docs.jci.com/tycofire/esfr-22_4-k-pend-rapid-install-sprinkler

General Description

The TYCO Model ESFR-22 22.4 K-Factor Pendent Rapid Install Sprinkler (RIS), herein called the ESFR-22 RIS, is an Early Suppression, Fast Response (ESFR) sprinkler with a pre-installed rubber RIS gasket for quick and easy installation. The ESFR-22 RIS threads into a TYCO RIS welded fitting by hand without the need for tape or sealant. The sprinkler assembly is shown in Figure 1.

The ESFR-22 RIS is a suppression-mode sprinkler that is especially advantageous as a means of eliminating the use of in-rack sprinklers when protecting high-piled storage.

The ESFR-22 RIS sprinkler is primarily used for ceiling-only sprinkler protection of, but not limited to, the following storage applications:

- Most encapsulated or non-encapsulated common materials including cartoned, unexpanded plastics
- Uncartoned (exposed) expanded plastics in accordance with the National Fire Protection Association (NFPA) standard NFPA 13 and FM Global standards.
- Some storage arrangements of rubber tires, roll paper, flammable liquids, aerosols, and automotive components

For more specific criteria, see Table B and the applicable design standard.

The ESFR-22 RIS provides the system designer with hydraulic and sprinkler placement options not presently available to the traditional ESFR sprinklers with nominal K-factors of 14.0 and 16.8. In particular, the ESFR-22 RIS is designed to operate at substantially lower-end head pressures, as compared to ESFR sprinklers with nominal K-factors of 14.0 and 16.8. This feature offers flexibility when sizing system piping, as well as possibly reducing or eliminating the need for a system fire pump.

The ESFR-22 RIS can eliminate the use of in-rack sprinklers when protecting high-piled storage of specific materials up to the following heights:

- NFPA: 40 ft (12,2 m) with ceilings up to 45 ft (13,7m)
- FM: 45 ft (13,7 m) with ceilings up to 50 ft (15,2 m)

For more specific criteria, see Table B and the applicable design standard.



NOTICE

The TYCO Model ESFR-22 Pendent Rapid Install Sprinklers described herein must be installed and maintained in compliance with this document, as well as with the applicable standards of the NATIONAL FIRE PROTECTION ASSOCIATION, in addition to the standards of any authorities having jurisdiction, such as FM Global. Failure to do so may impair the performance of these devices.

The owner is responsible for maintaining their fire protection system and devices in proper operating condition. Contact the installing contractor or product manufacturer with any questions.

In all cases, the appropriate NFPA or FM Global installation standard, or other applicable standard, must be referenced to ensure applicability and to obtain complete installation guidelines. The general guidelines in this data sheet are not intended to provide complete installation criteria.

Sprinkler Identification Number (SIN)

See Table A

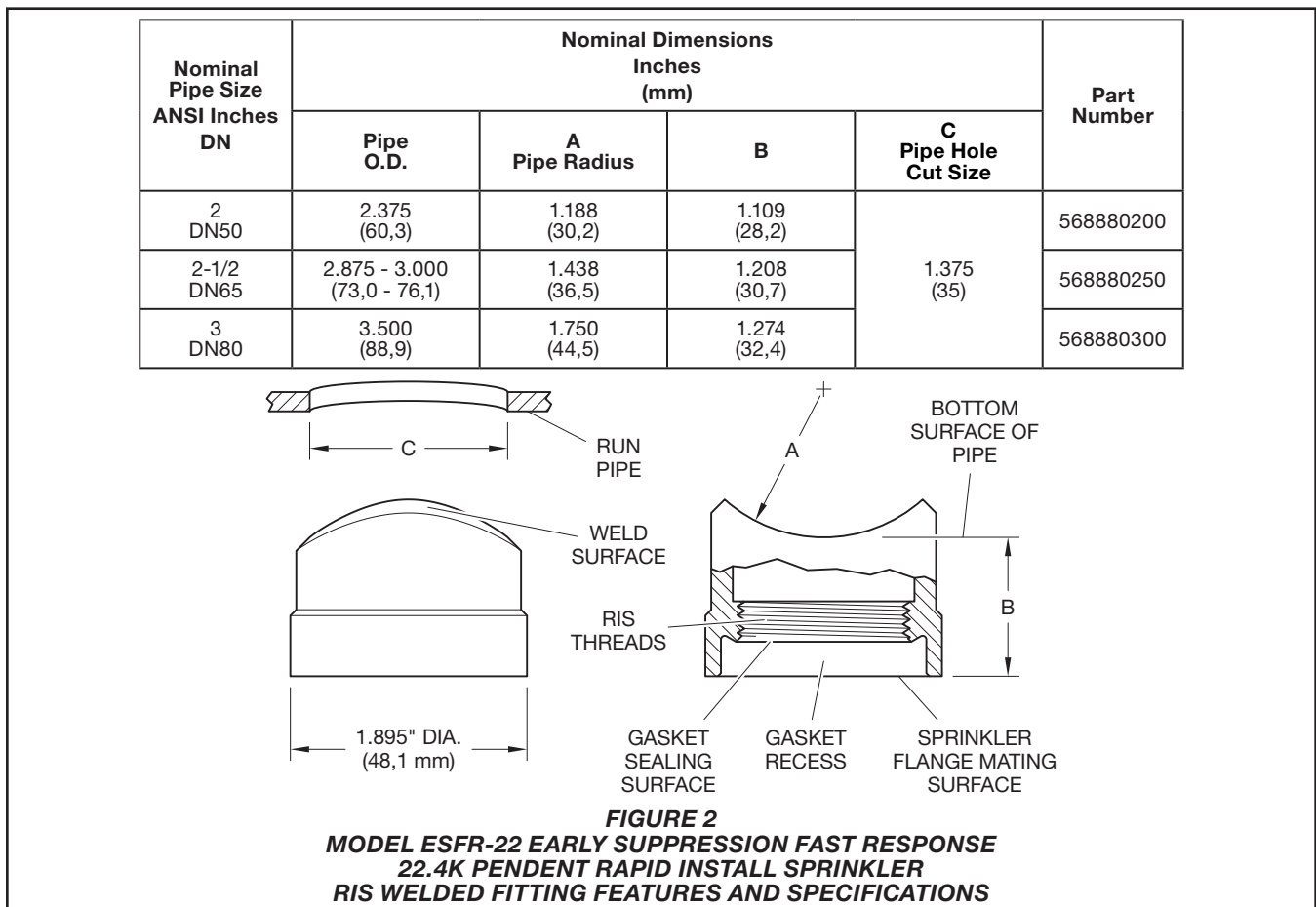
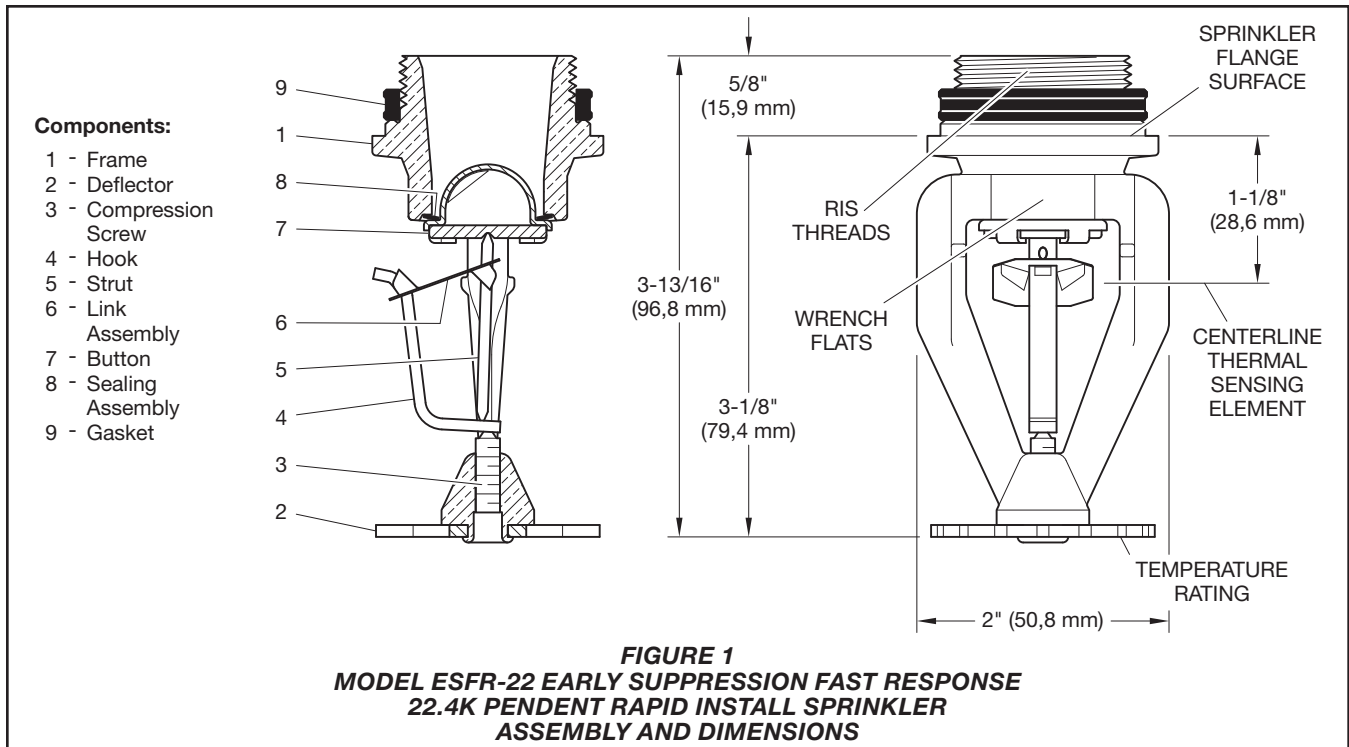

Storage Type	NFPA	FM Global
Sprinkler Type	ESFR	Storage
Response Type	FR	QR
System Type	Wet	Wet
Temperature Rating °F (°C)	165°F (74°C) 212°F (100°C)	165°F (74°C) 212°F (100°C)
Open Frame (i.e., no solid shelves), Single, Double, Multiple-Row, or Portable Rack Storage of Class I-IV and Group A or B Plastics	Refer to NFPA 13	Refer to FM Global 2-0 and 8-9
Solid Pile or Palletized Storage of Class I-IV and Group A or B Plastics	Refer to NFPA 13	Refer to FM Global 2-0 and 8-9
Idle Pallet Storage	Refer to NFPA 13	Refer to FM Global 2-0, 8-9, and 8-24
Rubber Tire Storage	Refer to NFPA 13	Refer to FM Global 2-0 and 8-3
Roll Paper Storage (Refer to the Standard)	Refer to NFPA 13	Refer to FM Global 8-21
Flammable/Ignitable Liquid Storage (Refer to the Standard)	Refer to NFPA 30	Refer to FM Global 7-29
Aerosol Storage (Refer to the Standard)	Refer to NFPA 30B	Refer to FM Global 7-31
Automotive Components in Portable Racks (Control mode only; refer to the Standard)	N/A	N/A

N/A – Not Applicable

TABLE B
MODEL ESFR-22 EARLY SUPPRESSION FAST RESPONSE
22.4K PENDENT RAPID INSTALL SPRINKLER
COMMODITY SELECTION AND DESIGN CRITERIA OVERVIEW

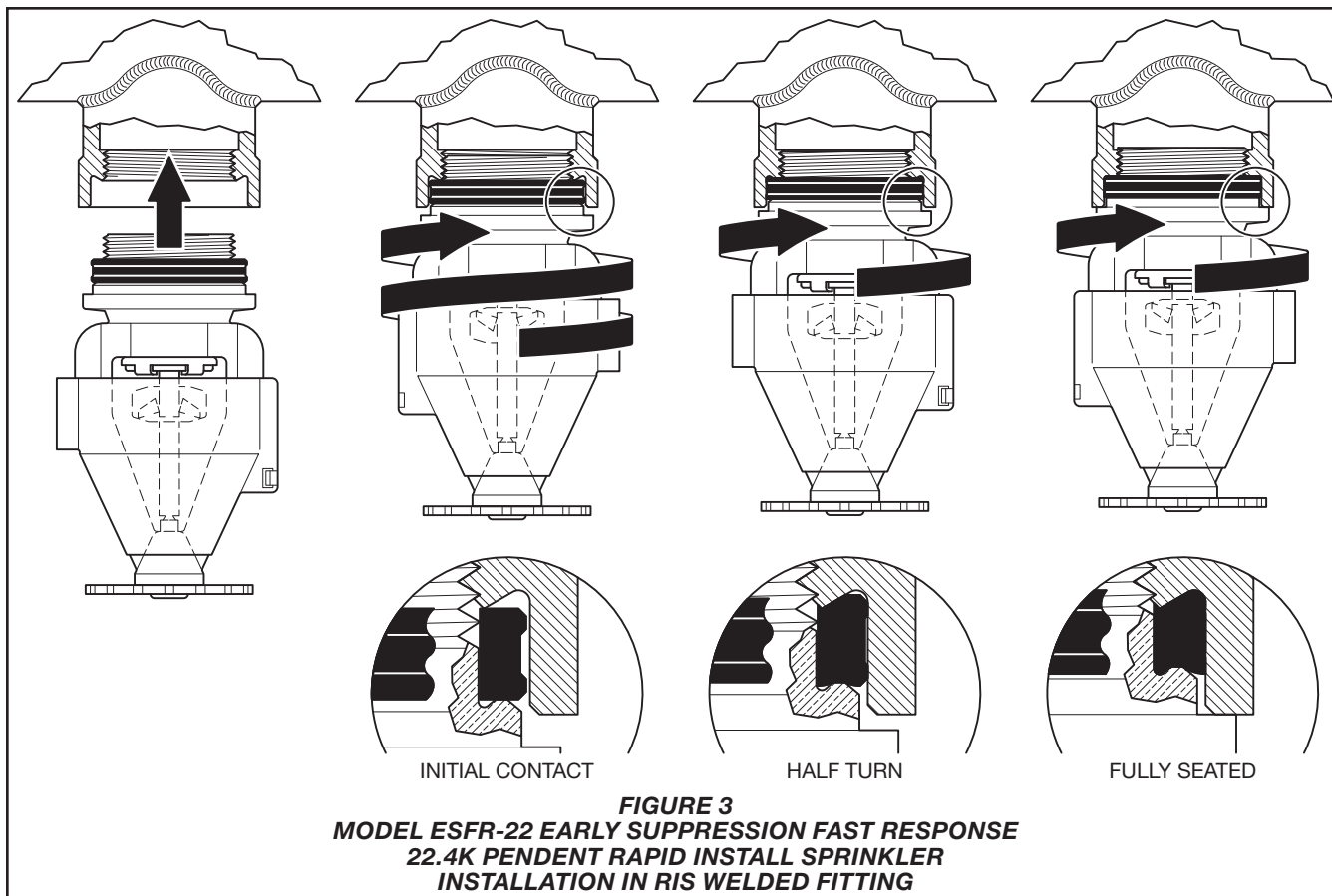

FIGURE 3
MODEL ESFR-22 EARLY SUPPRESSION FAST RESPONSE
22.4K PENDENT RAPID INSTALL SPRINKLER
INSTALLATION IN RIS WELDED FITTING

Installation

The TYCO Model ESFR-22 Pendent Rapid Install Sprinkler must be installed in accordance with this section. Read the General Instructions section before proceeding to the relevant installation instructions.

Note: Model ESFR-22 RIS assemblies and RIS plugs, see Figure 7, include a factory-assembled RIS gasket.

General Instructions

Observe the following guidelines while installing the sprinkler.

NOTICE

Ensure the sprinkler threads are clean and do not apply sealant such as tape or paste. Threads with debris or sealant could cause damage or impairment.

NOTICE

Do not apply pressure to the fusible link assembly. Failure to avoid this can lead to an unstable link assembly and premature activation of the sprinkler. Damaged sprinklers must be replaced.

- To avoid damaging the fusible link assembly during installation, ensure the factory-assembled link

protector remains attached to the sprinkler, and handle the sprinkler by the frame arms only as shown in Figure 5. Use only the appropriate sprinkler alignment tool as shown in Figure 6.

- To achieve a sound weld between the pipe and RIS welded fitting, ensure the surfaces of the pipe and RIS welded fitting near the joint area are free from porosity and indentations. Remove all surface contaminants such as oil, grease, loose paint, and dirt particles from the joint area before welding.
- Use an alignment welding cone to aid with aligning the RIS welded fitting and pipe during automatic welding practices. Fabricate the cone according to the 1 in. RIS Sprinkler Alignment Welding Cone Specifications available on www.tyco-fire.com.
- Ensure the RIS gasket is present on the ESFR-22 RIS and positioned at the base of the threads near the flange as shown in Figure 1.
- Do not remove the black protective coating inside the RIS welded fitting surface.
- Before painting or powder coating the RIS welded fitting, mask off the

fitting lip as shown in Figure 8. For example, 1-7/8 in. (4,76 mm) high temperature polyester masking discs or a high temperature 2 in. (5,08 mm) ceramic magnet may be used to mask the fitting.

Installing the Sprinkler

Note: The ESFR-22 RIS must be installed only in RIS welded fittings and cannot be installed in standard fittings featuring NPT or ISO tapered threads.

Step 1. Thread the ESFR-22 RIS by hand into the RIS welded fitting until the RIS gasket makes initial contact as shown in Figure 3.

Step 2. Continue to rotate the ESFR-22 RIS by hand a minimum of a 1/2 turn, through fully seating the sprinkler to produce a water-tight seal as shown in Figure 3. Adjust the sprinkler within this range to align the frame arms to the branch line.

(Optional) Use the alignment tool as shown in Figure 6 for more leverage.

See Figure 4 for QR code to access demonstration video.

Note: Data rates may apply.



FIGURE 4
RIS INSTALLATION
SCAN QR CODE TO ACCESS
DEMONSTRATION VIDEO

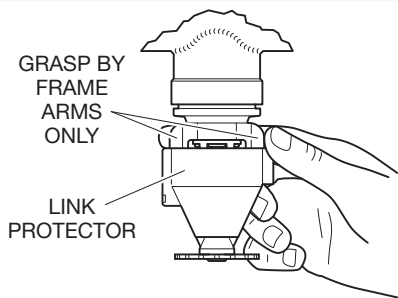

FIGURE 5
RIS WELDED FITTING
INSTALLATION HANDLING

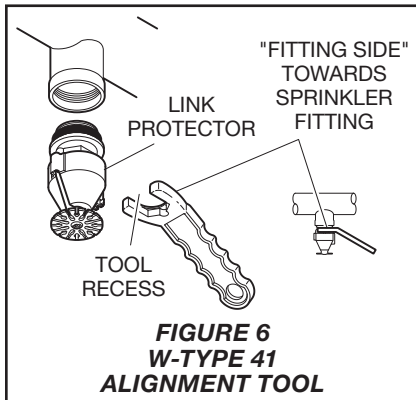

FIGURE 6
W-TYPE 41
ALIGNMENT TOOL

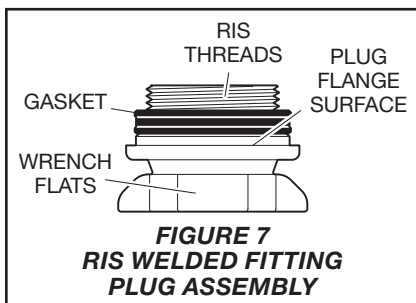

FIGURE 7
RIS WELDED FITTING
PLUG ASSEMBLY

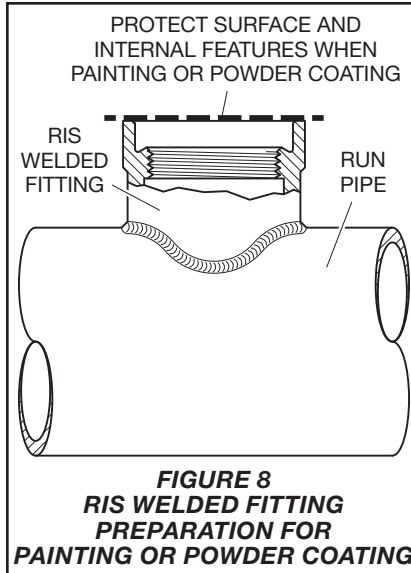

FIGURE 8
RIS WELDED FITTING
PREPARATION FOR
PAINTING OR POWDER COATING

Care and Maintenance

The TYCO Model ESFR-22 22.4 K-Factor Pendent Rapid Install Sprinklers must be maintained and serviced in accordance with this section.

Before closing a fire protection system main control valve for maintenance work on the fire protection system that it controls, obtain permission to shut down the affected fire protection system from the proper authorities and notify all personnel who may be affected by this action.

Sprinklers which are found to be leaking or exhibiting visible signs of corrosion must be replaced.

Automatic sprinklers must never be painted, plated, coated, or otherwise altered after leaving the factory. Modified sprinklers must be replaced. Sprinklers that have been exposed to corrosive products of combustion, but have not operated, should be replaced if they cannot be completely cleaned by wiping the sprinkler with a cloth or by brushing it with a soft bristle brush.

Care must be exercised to avoid damage to the sprinklers before, during, and after installation. Sprinklers damaged by dropping, striking, wrench twist/slippage, or similar mishandling, must be replaced. In the event that an RIS gasket is damaged, or the sprinkler needs to be reinstalled, the RIS gasket must be replaced.

The owner is responsible for the inspection, testing, and maintenance of their fire protection system and devices in compliance with this document, as well as with the applicable standards of the National Fire Protection Association such as NFPA 25, in addition to the standards of any authorities having jurisdiction. Contact the installing contractor or product manufacturer with any questions.

Automatic sprinkler systems are recommended to be inspected, tested, and maintained by a qualified Inspection Service in accordance with local requirements and/or national codes.

Limited Warranty

For warranty terms and conditions, visit www.tyco-fire.com.

Ordering Procedure

Contact your local distributor for availability. When placing an order, indicate the full product name and part number (P/N).

Sprinkler Assemblies

Specify: Model ESFR-22 Early Suppression, Fast Response 22.4K Pendent Rapid Install Sprinkler (TY8220), (specify temperature rating), P/N (specify):

165°F (74°C)	58-468-1-165
212°F (100°C)	58-468-1-212

RIS Welded Fitting

See Figure 2 for size and part number selection.

Specify: RIS Welded Fitting, Pipe Size (specify), P/N (specify)

RIS Welded Fitting Plug Assembly

Specify: RIS Welded Fitting Plug Assembly, P/N 56-888-0-102

RIS Gasket

Specify: ESFR RIS Gasket, 1 in., P/N 91-448-1-001

Note: See the Care and Maintenance section for replacement requirements.

Alignment Tool

Specify: W-Type 41 Alignment Tool, P/N 56-888-0-001